



## **RIDERS ROUNDUP**

### **for**

# **October/November 2003**

### **ROSIES RAMBLES**

Sorry for the lateness of this newsletter. But as they say, better late than never. Firstly I cannot thank the North Island Clubs enough who rallied around to make sure that NITE is a happening event. Well done everyone for volunteering time, effort, people so that we can meet in Taupo and have a fabulous time.

If your Club still holds a Cup or Trophy from last years NITE, please make sure that it gets to Helen (our National Secretary) before NITE or that someone from your Club brings it to the competition when you come. Can you make sure that it is engraved with your Clubs details and also that it is clean.

I hope that the South Island Clubs will be able to announce a similar working together in the very near future

Still have a few Clubs that have yet to put in their Affiliation forms. These were due way back in July following the National AGM, but as I said in my first statement, Better late than never!

National Committee will be holding a Committee meeting at NITE, you are invited to attend and meet the people who wear the label National Committee.

To those people who have to work over the Silly Season, take care and to those of us who can enjoy a break remember to take it easy so that you don't get to meet some of those who have to work. .. (the Drs, nurses, cops etc)

Safe riding, Rosemary



## PEGASUS RIDING CLUB

### PO BOX 4463, CHRISTCHURCH

The Pegasus Riding Club was formed in July 1982 by fifteen founding members. Their chief aim was to encourage riding as a sport and recreation, to promote good fellowship amongst riders and to improve and maintain a standard of riding and horsemanship. We have carried their dream on and 20 years later this club is one of the main clubs in the Canterbury area.

Due to the wide range of members the club has and their assortment of age and ability of both horse and rider, we endeavor to cater for all their levels. We hold monthly rallies which can include dressage, jumping, in-hand, show preparation, vetting and general health, feeding, etc. throughout the year.

At regular intervals during the year we hold competitions such as a Dressage Competition, Clear Round Show Jumping, Hunter/Derby Jumping Competition, Open Ridden Show, Closed Christmas Ridden Show and an In-hand Show. Admittedly we may not get to do all of these in a one year period, however, we do our best to please all of our members and give them a chance to get out there and mingle.

There are also a couple of team's events that we participate in annually, these being the Harris Teams Trophy for Dressage and the Dressage and Derby Day (which was started by Pegasus Riding Club in 2003).

Pegasus Riding Club annually award trophies to their members. Members can compete for the following:

- \* Attendance
- \* Turnout
  
- \* Best Riding Club Mount
- \* Most Improved Rider
  
- \* Most Improved Horse
- \* The Bestest, Fairest Horse
- \* Rebecca Arnold Memorial Cup - for sportsmanship

Like many other Riding Clubs in the Canterbury area, we don't own our own grounds, but we frequent many of the Pony Club grounds in the area. We move around these grounds as our members are wide spread over the area.

Our committee members are always trying to come up with new ideas for rallies and competitions and we encourage ideas from all our members as we are carrying on the initial commitment of our founding members by helping, encouraging and improving both the horse the rider.

For further information on our club or if you want to join contact any of the members as listed below.

#### COMMITTEE MEMBERS

President	Vice President	Secretary	Treasurer	Newsletter Editors
Lanie Astley	Verena Pritchard	Robyn Day	Nicola Parrott	Sarah Garret & Rachel Garret
PO Box 19837	PO Box 3	8 Neptune Place		PO Box 151
Woolston	WOODEND	North New Brighton		Tai Tapu
CHRISTCHURCH	PH 03 312 7010	CHRISTCHURCH		CANTERBURY
PH 03 384 9988		PH 03 382 5782		PH 03 325 3148

## THE HORSE STILE

This stile was first used in Australia to allow horses in to areas where they didn't want trail bikes or other vehicles. Apparently they tried several ideas, but this was the one that worked the best. The stile is set into the fence line, and does not necessarily have to be on a formed track or next to a gate.

We have seen it in use at Belmont Regional Park (near Wellington) when we were part of a group which included large horses and small ponies, plus our two horses who had

never seen anything like it before all of them coped perfectly well with it. If you have any doubts about your horse going through it you could practice with cavaletti at home first

Here is a drawing of the stile. The construction does have to be quite strong. It can be made from metal pipe as an alternative to wooden posts and poles. With wooden poles it may be a good idea to reinforce them with angle iron so that they can withstand someone trying to drive through them or chainsaw through them (or perhaps even a horse accidentally stepping on them). Alternatively, a piece of heavy wire stapled to the sides of the poles can be a good chainsaw deterrent.

In the Wellington region we have found the people managing recreational areas are keen to see more use of park areas and trails, including horse riding. It is only in areas that are really popular for picnics and short walks that there can be a conflict between the general public and riders. In other parts trampers and horse riders use the same trails with no problems. The problem is keeping out trail bikes and unauthorised 4WDs, and this usually means locked gates which effectively exclude horse riders as well. Often you can get a key, but they don't want to issue lots of keys because then it is easier for the wrong people to get hold of them and then the bikes etc are back in again. The Horse Stile is a better way of ensuring access for horse riders while still keeping vehicles out.

Glenn Fitzgerald, Bridleways Convenor

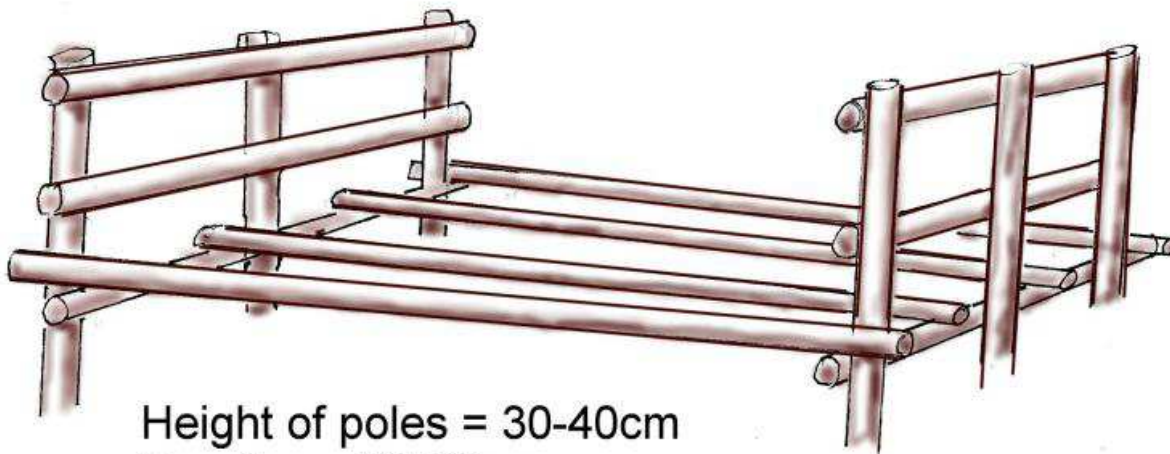

Height of poles = 30-40cm  
Spacing = 50-60cm

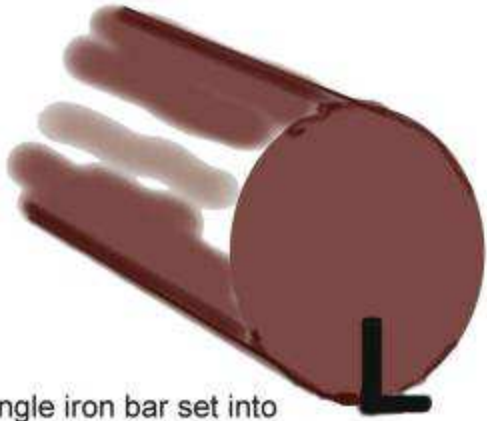

Angle iron bar set into bottom of pole to prevent cutting



YOU'RE CUNNING, SLY,  
CRAFTY, SHIFTY, WILY,  
SELF-CENTRED,  
LAZY AND ARTFUL.



YOU'RE PERFIDIOUS, INSIDIOUS, DEVIIOUS,  
EQUIVOCAL AND MACHIAVELLIAN.



AND, FOR A DUMB  
ANIMAL, THAT'S  
NOT BAD

